

Precitech has more Fast Tool Servo (FTS) systems in use worldwide than any other supplier. Over the last 20 years Precitech has delivered over 500 FTS systems.

FTS systems provide a rapid method to fabricate free form surfaces including: light management micro-structures, toric optics and mechanical features in contact lenses, lens arrays and laser collimators. FTS cutting is typically 10-15 times faster than other servo tool cutting methods (e.g. slow tool servo).

Precitech FTS units can be added to all Precitech ultra-precision Nanoform and Freeform systems. The FTS 35 has 35 μm of usable stroke and a maximum operating frequency of 1 kHz. The FTS 70 has a 70 μm stroke and a max operating frequency of 900 Hz. Tool movement is actuated by a piezo ceramic device and position feedback is provided by capacitive gage at 0.5 nm resolution. The FTS 70/35 use “one to one” piezo movement to tool movement technology with high stiffness flexures maximizing tool moment stiffness.

Overview

Model	FTS 70	FTS 35
Travel	70 μm \approx 100 Hz	35 μm \approx 140 Hz
Peak Acceleration	3000 m/s^2	5000 m/s^2
Typical Form	< 0.3 μm PV	< 0.2 μm PV
Typical Finish	< 3 nm Sa	< 2 nm Sa
Servo Band Width	900 Hz	1000 Hz
FastCom Control System		
Operating System:	Windows 7	
DSP:	Sharc ADSP	
Typical position command update rate:	20 to 35 kHz	
D to A converter:	18 bit, ultra-low-noise	
Update time jitter:	< 50 ns	
GUI:	Windows based UPx style	
Two optional packages		
Fiducial library – Programing objects defining the cutting path for frequently used fiducial (alignment) marks		
20th order aspheric lens arrays with blend zones and on-the-fly tool compensation		

FTS systems are controlled by Precitech’s exclusive Fastcom III FTS fast command generator that provides closed loop position control of the Fast Tool Servo. It’s in two way communication with the main UPx control. Operators interact entirely with the UPx control while FTS programs are running. All FTS systems include is a separate PC with DSP running Precitech’s FastCom III as standard.

Fastcom III is also fully supported by Precitech DIFFSYS CAM software. Surfaces can be defined by mathematical expressions, by point clouds (up to 1,000,000 points) or by bitmaps.

Benefits of defining a surface by mathematical expression include:

- No “point cloud” related limitations on the size of the surface or on the fine definition of individual features.
- Tool path commands are generated without interpolation between the lower resolution points in a point cloud rendering a more accurate surface.



Light management array, 40 mm OD brass disk
620,000 lenses Lens pitch 45 μm , Lens form
250 μm R sphere.

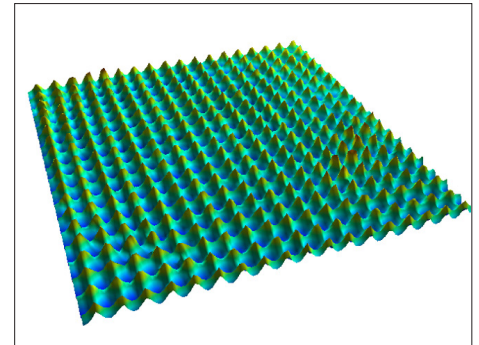

3D Metrology of micro lenses on the brass disk

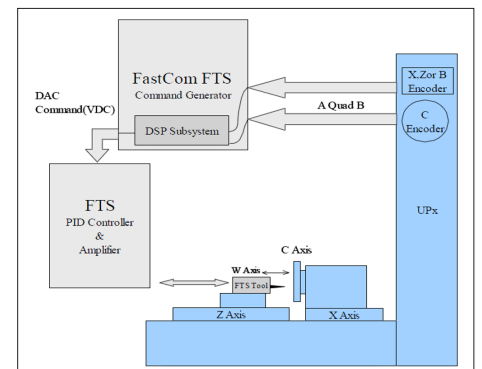

FTS control architecture